

Application of a Model-Based Fault Detection Approach on a Spacecraft

A.Alikhani^{1*}, Gh.Sharifi²

1. Aerospace Research Institute, Ministry of Science, Research and Technology, Tehran, Iran

2. Department of the Aerospace Engineering, K.N. Toosi University of Technology, Tehran, Iran

Abstract

The model-based fault detection approach is one of the software-based supervision systems monitoring. This method has a marked effect to detect components fault without demanding extra sensors to measure or add redundancy. The extended multiple model's adaptive estimation method is an online strategy to detect and isolation failure of components. Simple implementation, fast and accurate response, compatibility with nonlinear systems, and the ability to detect different types of faults are the most important features of this method. This method is applied to the faulty spacecraft in terms of actuators and its capability is evaluated. The most probable actuator fault implemented using MATLAB/SIMULINK software. The presented approach successfully detects faulty actuators.

Keywords: Fault detection, Spacecraft, model-based, EMMAE Method, Actuator Failure.

Introduction

Due to the importance, complexity, and cost of the space projects, increasing the reliability of system operation is vitally important. The main objective is to consider various unpleasant conditions and taking the required action within these faults or failures. In the monitoring process, all the required variables are checked and according to the considered range, all the undesired events are notified to the system management. In the other type, automatic action at some critical happening is taken based on the predesigns and preprogramming [1]. Diagnostics can be performed based on prior knowledge (model-based design according to mathematical principle) or driven empirically using numerous observation and experimental tests (like black-box models, neural networks) [2-4]. It should be those entire methods to formulate diagnostics use models (principles) and data, but their approaches have drastic differences.

Data-driven methods can be beneficial when the mathematical model of a physical system is complex and is not available. This approach is also used in [5] to detect gearbox faults by using an adaptive method. Capozzoli, Lauro, and Khan [6] implemented a data-driven method to commercial buildings to detect faults

as Duct fouling and excessive infiltration. It should be noted that the Data-driven methods require little information about systems operation which decreases the usage of engineering expertise and science. On the other hand, these approaches need a large volume of training data and are limited in extrapolation beyond the training data range.

There is an increasing interest in the development of model-based Fault Detection and Diagnostics (FDD) methods. The model-based strategy uses a priori knowledge to develop a physical system mathematically and by using this model can evaluate differences (residuals) between the actual operating states. This analytical analysis is often according to quantitative model-based methods, parity relations, observers, Kalman-filter, and parameter estimations techniques [7-10]. Gliel [11] employed stated observation to detect a fault in an industrial boiler. In aerospace vehicles, mostly the fault detection and diagnosis process relies on hardware and sensor redundancy [12]. But, since adding redundant hardware (due to some main reasons as space, weight, and cost limitations) is not possible, health monitoring through software has gained attention in recent years. In [13] and [14] two projects dealing with fault on the thrusters of the Mars Express

spacecraft and the wing-flap actuators of the HL-20 reusable launch vehicles are indicated.

Another approach to detect and isolate actuator or sensor faults is the multiple model adaptive estimation (MMAE) method which was successfully implemented on various vehicles like aircraft and underwater vehicles [15-16]. The main advantage of the MMAE method compared to other FDD algorithms lies in its responsiveness to parameter variations, leading to faster fault isolation than that attained by other methods without a multiple model structure. With a combination of MMAE with Extended Kalman Filter (EMMAE), to make the MMAE method applicable for any circumstances and systems, the MMAE algorithm is combined with EKF's used for the nonlinear estimation [17-18]. Due to the nonlinear nature of most dynamic systems, the method can be implemented on various systems.

The objective of this paper is to implement a model-based fault detection technique on a faulty spacecraft (considering faults in actuators). As mentioned, the EMMAE method has been applied to airplanes and underwater vehicles. In this paper, we demonstrate the capability of this method on a new vehicle. Since the operational environment, required accuracy and sensitivity to detect a fault, as well as the type of actuator mechanism, is drastically different from each other. Secondly, the mechanical and electrical features of actuators are completely varied from each other. An aileron mechanism is markedly a different system from a reaction wheel and some features as DC motor operation, vibration, saturation, speed of motion, etc., can't study on the aileron. Therefore, the second novelty is concerning fault implementation on a new type of actuator.

The paper is organized as follows: Section 2 deals with a brief explanation of the EMMAE method and the mathematical formulation of this technique. The satellite dynamics are represented in section 3. Simulation results of the system using Simulink/Matlab software and conclusions are provided in sections 4 and 5.

The Model-Based EMMAE Method

A supervisor system plays an important role to maintain system performance and increase reliability. This process performs a set of activities to maintain a system in operable condition by observing the system states. This chapter explains a high-performance online nonlinear FDD system that monitors the health of the actuators without demanding extra sensors. A high-performance approach to detect and diagnose faults on actuators or sensors is the EMMAE method as shown in Fig.1. It monitors the system's healthy based on a bank of Extended Kalman Filters (EKF's) running in parallel, which each of these EKF's corresponding to the specific fault of the actuators.

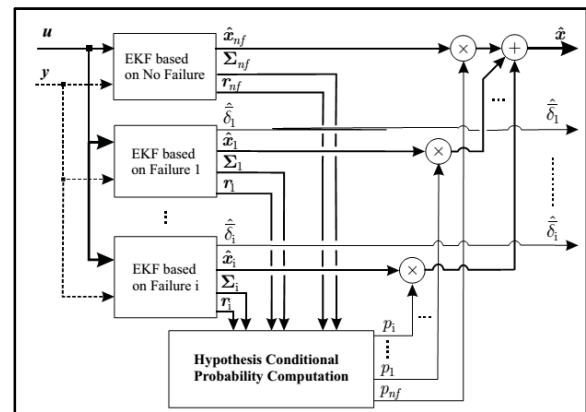

Figure 1. Classical EMMAE approach using EKF's [19]

This scenario has important advantages in contrast to others FDD approaches. The main advantage of the EMMAE method attributes the responsiveness to parameter variations and robustness against disturbances and platform uncertainties. Also, this method doesn't require a complex multiple model structure and can implement on the general microprocessor conveniently.

The other benefit is the ability to detect various fault occurrences on actuators based on different causes like delay, saturation, abruptness, etc. The EKF's are employed based on continuous nonlinear differential equations that describe the plant under consideration as follows [20]:

$$\dot{x} = f(x, u) + w \tag{1}$$

where the state vector is x , the control input vector is u , the set of nonlinear functions of the state and control vectors is $f(x, u)$, and the random zero-mean process noise vector is w .

The main equation to detect faults using the EMMAE method is explained [19].

The state vector of the i^{th} is augmented to monitor the actuator faults. This state is added to estimate during EKF estimation. Therefore the state vector for each filter i is:

$$z_i = \begin{bmatrix} x \\ \delta_i \end{bmatrix} \tag{2}$$

Where x is the system states and δ is the i^{th} faulty actuator.

The discretized form of Eq.1, as well as the discrete form of the measurement equations, expressed in state-space form as

$$\begin{aligned} x(k+1) &= \Phi_k x_k + G_k u_k + w_k \\ y_k &= h(x_k) + v_k \end{aligned} \tag{3}$$

where the state vector is evaluated at the discrete-time instant $t_k = KT_s$, and T_s is the sampling time of the process. The discrete transition matrix Φ_k is approximated by

$$\Phi_k \cong I + F_k T_s \tag{4}$$

where the continuous system dynamics matrix is F_k . The continuous system dynamics matrix F and G is the control-input matrix.

$$F_{zi}(k) = \frac{\partial}{\partial z_i} f_{zi}(z_i(k), \delta(k)) \Big|_{z_i = \hat{z}_i(k|k)} = \begin{bmatrix} F(k) & G^{(i)}(K) \\ 0 & 1 \end{bmatrix} \tag{5}$$

$$G_{zi}(k) = \frac{\partial}{\partial \delta_i} f_{zi}(z_i(k), \delta(k)) \Big|_{z_i = \hat{z}_i(k|k)} = \begin{bmatrix} G^{(0,i)}(K) \\ 0 \end{bmatrix} \tag{6}$$

Using the above equations, the linearized system evaluated at each sampling time can be shown as:

$$\begin{bmatrix} x(k+1) \\ \delta(k+1) \end{bmatrix} = \begin{bmatrix} F(k) & G^{(i)}(K) \\ 0 & 1 \end{bmatrix} \begin{bmatrix} x \\ \delta_i \end{bmatrix} + \begin{bmatrix} G^{(0,i)}(K) \\ 0 \end{bmatrix} \delta(k) \tag{7}$$

The probabilities of the system, either in the no-fault case or in an actuator/sensor failure case:

$$p_i[k] = p[\theta = \theta_i | Y_k] = \frac{p[y = y_k | (\theta = \theta_i, Y_{k-1})] \cdot p_i[k-1]}{\sum_{j=0}^N p[y = y_k | (\theta = \theta_j, Y_{k-1})] \cdot p_j[k-1]} \tag{8}$$

$$p[y = y_k | (\theta = \theta_i, Y_{k-1})] = \epsilon_i[k] e^{-r_i[k]^T \Sigma_i^{-1}[k] r_i[k] / 2} \tag{9}$$

$$\epsilon_i[k] = \frac{1}{2\pi^{m/2} |\Sigma_i(k)|^{1/2}} \tag{10}$$

By examining the probabilities computed by Eq.[8], we can determine the health status of the system, either in the no-fault case or in an actuator/sensor failure case. Since a fault may occur at any time, regardless of which actuator may fail, we decide to assign the same probability to all the scenarios, i.e., $p[\theta = \theta_j] = 1/N$ for $j = 1, N$. Term $|\dots|$ denotes the determinant of the matrix, m represents the measurement dimension, and $\Sigma_i(k)$ is the residual covariance matrix calculated at a time step by the i^{th} EKF. The term $r_i[k]$ corresponds to the residuals of the i^{th} EKF.

A Micro-Satellite platform as a case study

Due to the risk of space missions, spacecraft requires advanced monitoring systems to detect failures, hence it is an effective alternative to hardware redundancy. The most probable area in spacecraft for occurring a fault is in Attitude Control Subsystem (ACS), more particularly its actuators. These components are faced with unexpected faults/failures like cold solder joints, minute particles, or massive temperature fluctuations. Various actuators are employed on the satellite base on the mission as reaction wheel (RW), Momentum Wheel (MW), cold gas thruster, and magnetic torque. An RW that commonly use in imaging missions consists of a flywheel attached to a brushless DC motor. It's notable notably that at least three RWs are required for fully actuated attitude control [21].

Table 1 describes some of the recent momentum/reaction wheel failures in space missions.

Table 1. Summary of on-orbit failure of the actuator [22]

Spacecraft	Cause of anomaly	Year
Radarsat-1	2 pitch MWs failed	1999,
		2002
ISS	1 CMG failed on June 8	2002
Hayabusa	X and Y axis RW failed on July 31 and October 2, respectively	2005
FUSE	Final RW required for accurate pointing failed	2007
TIMED	Single RW failure	2007
Dawn	Two RW failures due to excessive friction development	2010,
		2012
Kepler	Two RW failures disabled accurate positioning/data collection	2012,
		2013

Since the reaction wheel is the most commonly used actuator in the satellite for various missions as imaging or telecommunications, this actuator is considered to study the performance of the proposed method. An example of the usage of RWs on a satellite is shown in Fig.2

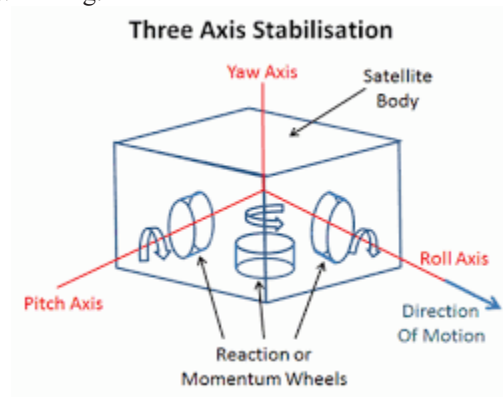

Figure 2. The Layout of attitude control using RWs

Mathematical Dynamics Equations

Euler equations are used to model the dynamics of the spacecraft, with respect to concerning an inertial coordinate system {I}. The reaction wheels are used as excitation actuators. The attitude dynamics of a rigid simulator are given by Euler's equation [21,23]:

$$\vec{M}_{ext} = J\dot{\vec{\omega}} + \vec{\omega} \times J\vec{\omega} - \vec{h}_{rw} - \vec{\omega} \times \vec{h}_{rw} \tag{11}$$

where J is the spacecraft's inertia matrix, $\omega = [\omega_x \ \omega_y \ \omega_z]^T$ is the angular velocity of body {B} in {I}, \vec{h}_{rw} is the angular momentum of the reaction wheels and \vec{M}_{ext} is the external torque which is applied on the platform. Also, this external torque contains various types as:

$$\vec{M}_{ext} = \vec{M}_{aero} + \vec{M}_{sun} + \vec{M}_g + \vec{M}_m \tag{12}$$

Where \vec{M}_{aero} is the aerodynamics torque, \vec{M}_{sun} is applied from solar pressure, \vec{M}_g is the major torque from gravity gradient and \vec{M}_m created from interacting of satellite with the magnetic field. The rotational kinematics using a quaternion can be described by

$$\begin{bmatrix} \dot{q}_1 \\ \dot{q}_2 \\ \dot{q}_3 \\ \dot{q}_4 \end{bmatrix} = \frac{1}{2} \begin{bmatrix} 0 & \omega_z & -\omega_y & \omega_x \\ -\omega_z & 0 & \omega_x & \omega_y \\ \omega_y & -\omega_x & 0 & \omega_z \\ -\omega_x & -\omega_y & -\omega_z & 0 \end{bmatrix} \tag{13}$$

where $q = [q_1 \ q_2 \ q_3 \ q_4]^T$ are the quaternions. The quaternion is defined as a vector in the following:

$$q = iq_1 + jq_2 + kq_3 + q_4 \tag{14}$$

Simulation result

In this section, the EMMAE method is performed on a micro-satellite and the simulation result using the Matlab/Simulink software is presented. The structure of Simulink software is classified into various sections as control algorithm, platform dynamics, the mathematical model of reaction wheels, supervisor system, and the FDD developed method. As can be seen in Fig.3 the simulation scenario is presented. To simulation this approach, a failure apply to one of the actuators (RW1 in this layout) and by considering the control torque and system states, the developed method, identifies the faulty actuator and report to the supervisor system to take necessary strategy. In this simulation, only the fault detection process is discussed. The main features of the satellite are considered as in Table 2.

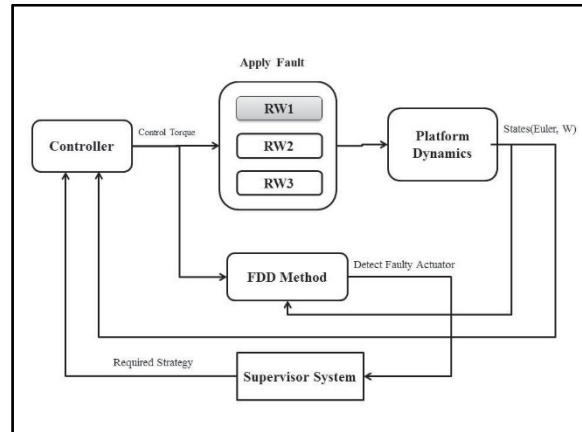

Figure 3. Simulation process

Table 2. The main features of the satellite

Title	Value
Moment of inertia (body)	$\begin{bmatrix} 5 & 0.1 & -0.02 \\ 0.1 & 5.5 & 0.07 \\ -0.02 & 0.07 & 6 \end{bmatrix} \text{Kg.m}^2$
Mass	80 kg
Moment of inertia (RW)	0.0004 kg.m ²
Max-Speed.RW	7000 rpm
RW number	3

Without Failure

First of all, a Slew maneuver without any fault occurrence is performed to ensure about simulation process and designed a Feedback quaternion controller. The initial condition [0, 0, 0] is considered and the platform is excited to achieve the desire attitude degree that is [70, 60, 30].

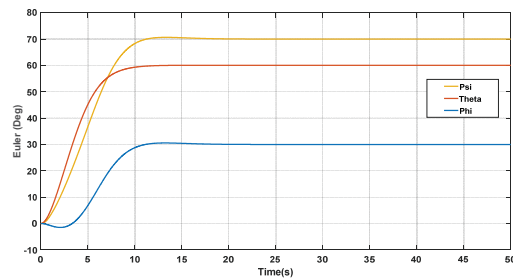

Figure 4. Satellite attitude maneuver

As can be observed a three-axis maneuver was implemented on the platform reaching the desired attitude below 20 sec using three reaction wheels as actuators. Also, the satellite angular velocities on the three axes are presented.

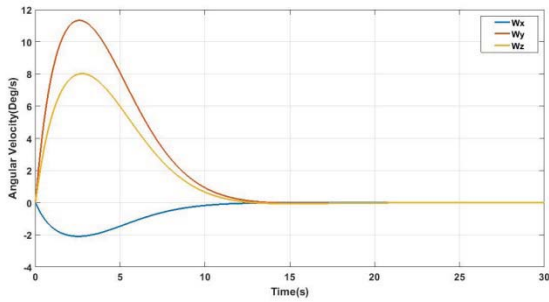

Figure 5. Satellite angular velocity

The angular velocity increased during the applied maneuver and provides sufficient stability at the end of the maneuver by reaching the desired attitude. The change of actuator velocity is also illustrated to describe this maneuver in detail.

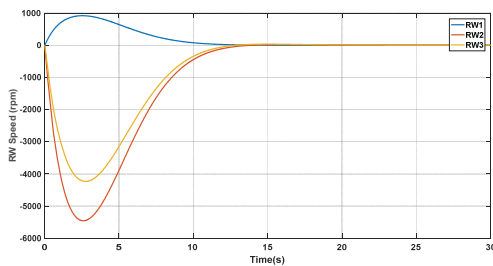

Figure 6. Reaction wheel angular velocity

It's evident that platform momentum remains constant during the mission; hence the satellite angular velocity and actuators are applied in the opposite direction. The maximum actuator velocity is under 6000 rpm and the difference between RW speeds is according to desired attitude as well as platform inertia about each axis. This simulation validates developed attitude controller performance and mission simulation without applying any fault. In the following, two critical failures on a reaction wheel [24,25] that is the main actuator in remote sensing satellite are studied; Change of the mechanical properties (saturation level) and complete failure (zero torque) are applied and performance of the EMMAE method to detect faults are studied.

Apply Fault

Case1:Zero-Torque

In this case, it's assumed that the actuator about X-axis failed from the beginning of the maneuver. This failure occurs due to problems with the power supply, connections, and wiring.

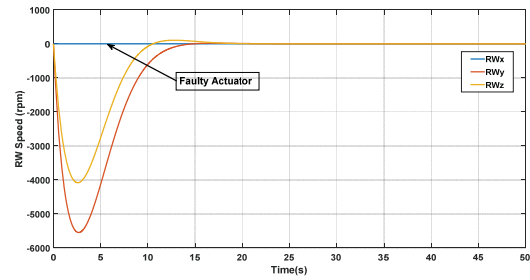

Figure 7. Occurrence failure on an actuator (Case1)

As can be observed, the reaction wheel about the x-axis dealt a defect and remains without any motion during the maneuver. The EMMAE method response in this condition is described in Fig.8. It should be noted that the initial probability of faulty condition has considered as [0.7, 0.1, 0.1, 0.1] which "No-fault" condition corresponding to 0.7. The probability of failure is considered equal due to the same reaction wheel manufacturer.

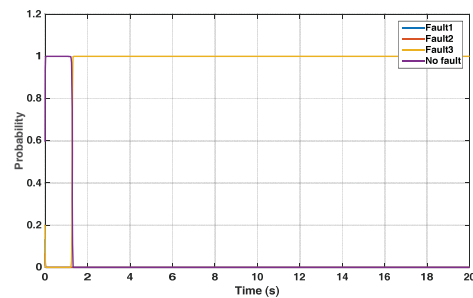

Figure 8. Actuators fault probability using EMMAE method

The developed method after getting its required data from measurement sensors can successfully detect the faulty actuator after 1 sec. At the beginning of the maneuver, due to the greater probability of No-Fault condition, the method report this mode and after obtaining sufficient data, the faulty actuator is correctly identified. The RW_x (Fault3) has been recognized as a faulty actuator and is reported to the health monitoring system. The attitude maneuver concerning this faulty condition is presented as:

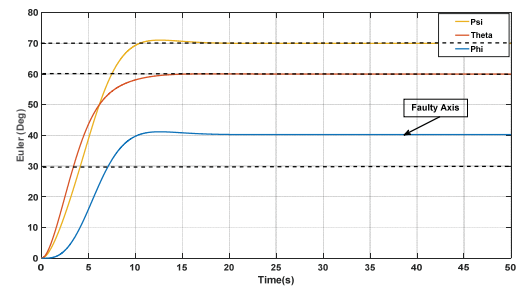

Figure 9. Satellite attitude maneuver during the faulty condition (Case1)

As can be observed Y and Z axis reach to desire attitude and the X-axis because of the RW failure hasn't addressed our target. Platform motion about this axis is due to non-linear dynamics of the systems as well as platform inertia. The dynamics of the system are coupled and the application of torque on each axis affects the other axes.

Case2:Saturation level

Since actuators are electromechanical devices, there is a possibility of changing their performance characteristics during the mission, which can be occurred due to the changes in the drivers, supplied voltage, and mechanical components. In this case, the saturation level of the reaction wheel changes from 7500 rpm to 1000 rpm.

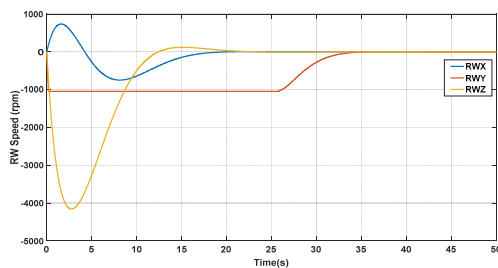

Figure 10. Occurrence failure on an actuator (Case2)

As can be seen, the saturation level of the RW_y has decreased from 7000 to 1000 rpm and no more torque is applied when it reaches this level. It's clear that between 2-28 sec RW_y doesn't apply any torque and its speed is fixed.

The comparison between expected torque and applied torque from RW_y is shown in Fig.11

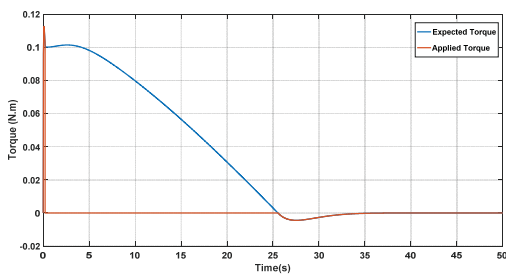

Figure 11. Comparison between required and applied torque by the actuator (Case2)

After the wheel speed reaches the saturation level, no torque is applied to the system, which is significantly different from the expected value. This difference leads to detect the desired fault by the algorithm. The EMMAE method can detect this fault properly.

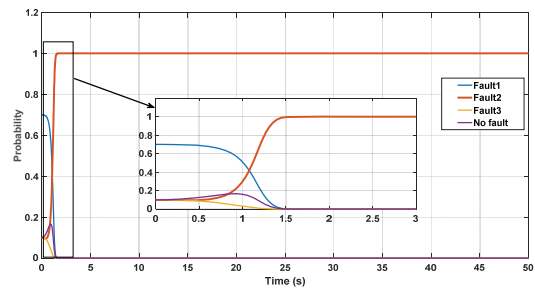

Figure 12. Actuators fault probability in case fault 2 using EMMAE method

Using the torque command applied by the controller and the attitude of the spacecraft, the method was able to correctly identify the faulty actuator in about 2 seconds. Fast response is one of the most important advantages of this method, which was well demonstrated in this test.

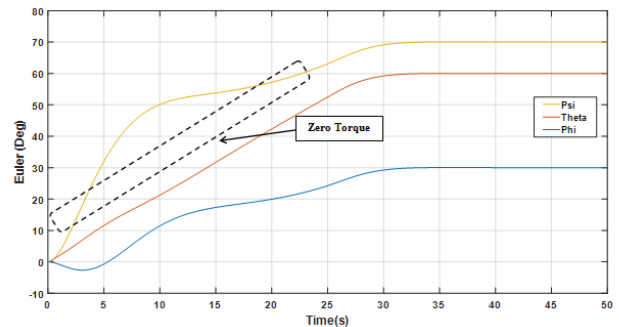

Figure 13. Satellite attitude maneuver during the faulty condition (Case2)

Changes in the angles of the axes are shown in figure 13. As can be seen, the existence of this defect has affected other axes due to the non-linear nature and coupling of the system dynamics. No torque is applied in the specified area and the system is rotating at a constant angular velocity until control torque is applied again in Sec 28. After applying the required torque, all three axes were able to track the desired attitude.

Conclusion

In this paper, different fault detection and diagnosis methods were introduced briefly and the Extended Multiple Model Adaptive Estimation (EMMAE) Method software-based monitoring approach explained in detail. The algorithm equations were explained and spacecraft dynamics equations to apply the proposed method, was indicated. Two critical failures on the reaction wheel that is the main actuator in satellite were studied; Change of the mechanical properties (saturation level) and complete failure (zero torque) were applied and the developed method can detect faulty actuator properly. During the algorithm simulation, the ability of the method to respond quickly,

identify different types of faults, and the stability of fault detection were validated.

References

- [1] Rolf Isermann, Model-based fault-detection, and diagnosis status and applications, Annual Reviews in Control, Volume 29, Issue 1, 2005, Pages 71-85, ISSN 1367-5788,
- [2] X. Yu, J. Jiang, A survey of fault-tolerant controllers based on safety-related issues, Annual Reviews in Control 39 (2015) 46–57.
- [3] Said, M., Abdellafou, K.b. & Taouali, O. Machine learning technique for data-driven fault detection of nonlinear processes. J Intell Manuf 31, 865–884 (2020).
- [4] S. Anwar, W. Niu, A nonlinear observer-based analytical redundancy for predictive fault-tolerant control of a steer-by-wire system, Asian Journal of Control 16 (2) (2014) 321–334.
- [5] Belsak, A., Flasker, J. (2008). Vibration analysis to determine the condition of gear units. *Strojniški Vestnik - Journal of Mechanical Engineering*, vol. 54, no. 1, p. 11-24
- [6] Capozzoli, A., F. Lauro, and I. Khan. 2015. "Fault Detection Analysis Using Data Mining Techniques for a Cluster of Smart Office Buildings." *Expert Systems with Applications*. 42:4324–4338.
- [7] Bouallègue, W.; Bouslama Bouabdallah, S.; Tagina, M. Causal approaches and fuzzy logic in FDI of Bond Graph uncertain parameters systems. In Proceedings of the IEEE International Conference on Communications, Computing and Control Applications (CCCA), Hammamet, Tunisia, 3–5 March 2011
- [8] Thirumarimurugan, M.; Bagyalakshmi, N.; Paarkavi, P. Comparison of fault detection and isolation methods: A review. In Proceedings of the 2016 10th International Conference on Intelligent Systems and Control (ISCO), Coimbatore, India, 7–8 January 2016.
- [9] Li, Xifeng & Xie, Yongle & Bi, Dongjie & Ao, Yongcai. (2013). Kalman Filter-Based Method for Fault Diagnosis of Analog Circuits. *Metrology and Measurement Systems*. 20. 10.2478/mms-2013-0027.
- [10] Skliros, C., Esperon Miguez, M., Fakhre, A., Jennions, I. (2019). A review of model-based and data-driven methods targeting hardware systems diagnostics. *Diagnostyka*, 20(1), 3-21. <https://doi.org/10.29354/diag/99603>
- [11] Geliel, Mostafa & Zakzouk, Sherief & Sengaby, M.. (2012). Application of model-based fault detection for an industrial boiler. 2012 20th Mediterranean Conference on Control and Automation, MED 2012 - Conference Proceedings. 98-103. 10.1109/MED.2012.6265621.
- [12] E. Khalastchi and M. Kalech. A sensor-based approach for fault detection and diagnosis for robotic systems. *Autonomous Robots*, 42(6):1231–1248, Aug. 2018.
- [13] Patton, R.; Uppal, F.; Simani, S.; Polle, B. Robust FDI applied to thruster faults of a satellite system. *Control Eng. Pract.* 2010, 18, 1093–1109.
- [14] Falcoz, A.; Henry, D.; Zolghadri, A. Robust Fault Diagnosis for Atmospheric Reentry Vehicles: A Case Study. *IEEE Trans. Syst. Man Cybern. Part A Syst. Hum.* 2010, 40, 886–899.
- [15] R. Isermann. *Fault-Diagnosis Systems, An Introduction from Fault Detection to Fault Tolerance*. Springer-Verlag, Berlin Heidelberg, 2006
- [16] L. Ni. *Fault-Tolerant Control of Unmanned Underwater Vehicles*. PhD thesis, VA Tech. Univ., Blacksburg, VA, 2001.
- [17] M. Azam, K. Pattipati, J. Allanach, S. Poll, and A. Petterson-Hine. In-Flight Fault Detection and Isolation in Aircraft Flight Control Systems. In Proceedings of IEEE Aerospace Conference, 2005. Paper 1429.
- [18] G. Ducard and H. P. Geering, "A reconfigurable flight control system based on the EMMAE method," 2006 American Control Conference, Minneapolis, MN, 2006, pp. 6 pp.-, DOI: 10.1109/ACC.2006.1657599.
- [19] Ducard, G.. (2009). *Fault-tolerant Flight Control and Guidance Systems: Practical Methods for Small Unmanned Aerial Vehicles*. 10.1007/978-1-84882-561-1.
- [20] M.S. Grewall, A.P. Andrews. *Kalman Filtering. Theory and Practice*. Prentice-Hall, 1993
- [21] Marcel Sidi, "Spacecraft Dynamics & Control," Cambridge university press, 1997
- [22] R. Cowen, "The wheels come off Kepler," *Nature*, vol. 497, no. 7450, pp. 417–418, May 2013.
- [23] Ghasem Sharifi & Ehsan Zabihiyan (2020) An effective approach to identify the mass properties of a satellite attitude dynamics simulator, *Australian Journal of Mechanical Engineering*, 18:3, 245254, DOI: 10.1080/14484846.2018.1458811
- [24] A. Mohammad and S. M. B. Billah, "Analysis of speed control of series DC motor using diverter and observation of speed saturation point," 2015 International Conference on Electrical Engineering and Information Communication Technology (ICEEICT),

Dhaka, 2015, pp. 1-4, DOI:
10.1109/ICEEICT.2015.7307350.
[25] A. Adouni, A. Abid and L. Sbita, "A DC motor
fault detection, isolation and identification
based on a new architecture Artificial Neural

Network," 2016 5th International Conference
on Systems and Control (ICSC), Marrakesh,
2016, pp. 294-299, DOI:
10.1109/ICoSC.2016.7507054.